



HIT-44 DRILL MASTER OWNERS MANUAL



**WHEN USING POWER TOOLS
ALWAYS WEAR
EYE AND EAR PROTECTION!!**

1825 VIA BURTON ANAHEIM, CA 92806 (714) 772-5202 FAX (714) 772-2302
WEBSITE: WWW.MAJORMFG.COM E-MAIL: MAIL@MAJORMFG.COM

THINK SAFETY!!

**WHEN USING POWER TOOLS
ALWAYS WEAR
EYE PROTECTION!!**

Before attempting any installation know how to safely use the power tools involved. Be sure all bits and cutters are sharp and in good condition and all power tools and extension cords are in good working order and properly grounded. **AND MOST IMPORTANTLY, BE SURE TO WEAR, EYE AND EAR PROTECTION.**

HIT-44 ADJUSTMENTS



To adjust for 2-3/8" or 2-3/4" backset locks, just rotate the backset knob both on the top and bottom.



Using the supplied allen wrench, install the proper size break out plate/hole saw guide. Two 1-1/2" and two 2-1/8" guides are supplied. For wood door use mount with the washers on top of the break out plate. For steel door use, mount with the washers under the break out plate. Remove the multi-spur guide on opposite side and replace with another guide as shown in picture.



There are three drill guide bushings supplied with the HIT-44 for use when drilling the edge bore, they are held in with a clip. Choose from a 7/8", 1" or the brass guide for use with a multi-spur bit, they just snap in.

ADJUSTING THE LATCH HOLE CENTERING FEATURE

The HIT-44 is unique in the fact that the latch or edge bore hole can be adjusted to drill on center or offset. To check for centering, just turn the main clamp knob until the right and left hand jaws are flush with the cut out in the core. If they are both flush the HIT-44 will drill a centered latch hole. To adjust centering or set up for an offset hole see next page.

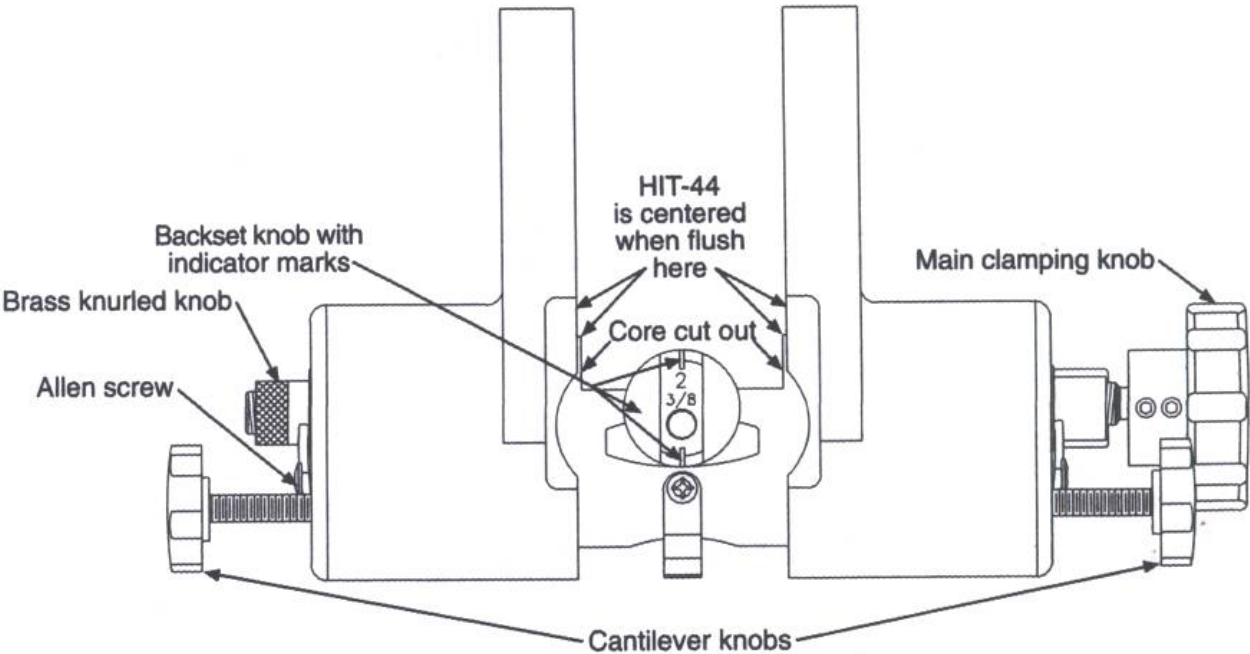

TO ADJUST CENTERING

HIT-44 IS CENTERED WHEN
RIGHT AND LEFT HAND JAW
IS FLUSH WITH CORE CUT
OUT



The HIT-44 has a unique feature in the fact the centering can be adjusted. This will allow you to drill a centered latch hole in the edge of the door or one that is off centered. This is handy in case a door has an additional skin or plywood added on for re-enforcement. By loosening the allen screw holding the brass KNURLED knob and you can move one jaw independent from the other. This will move the centering of the latch hole by the amount you moved the jaw. Adjust the knob until you have the hole where you want it. Tighten the allen screw and drill the latch hole. It is a good idea to re-center your drill guide after use so a door won't be mis-drilled next time. To re-center, turn the large main clamp knob until the clamp jaw on that side is flush with the core cut out . Loosen the brass KNURLED knob on the opposite side and adjust that jaw until it is also flush with the core cut out. Tighten the allen screw and the unit is now centered.

USING THE HIT-44



Prior to clamping the HIT-44 to the door, check to make sure the backset adjustment knobs correspond to the lock you are installing. A 180 degree turn of the knob will change the backset to 2-3/8" or 2-3/4"



Clamp the HIT-44 to the door with a light pressure, just enough to hold it on the door.



Now tighten the black plastic cantilever knobs until snug.

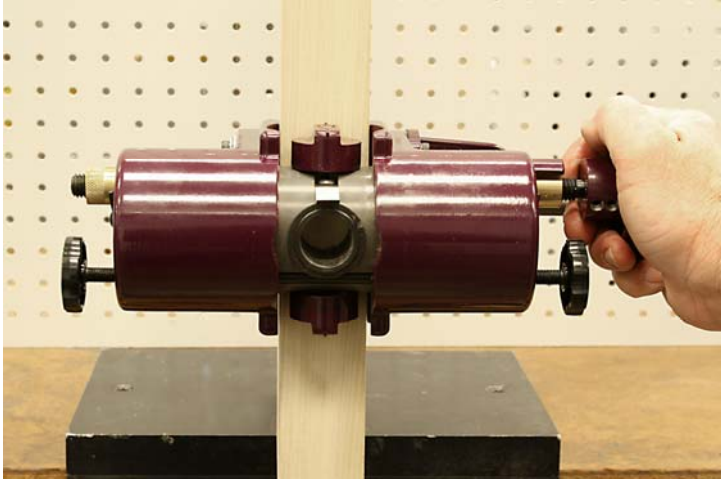

One final turn of the main clamp knob will secure the HIT-44 to the door.

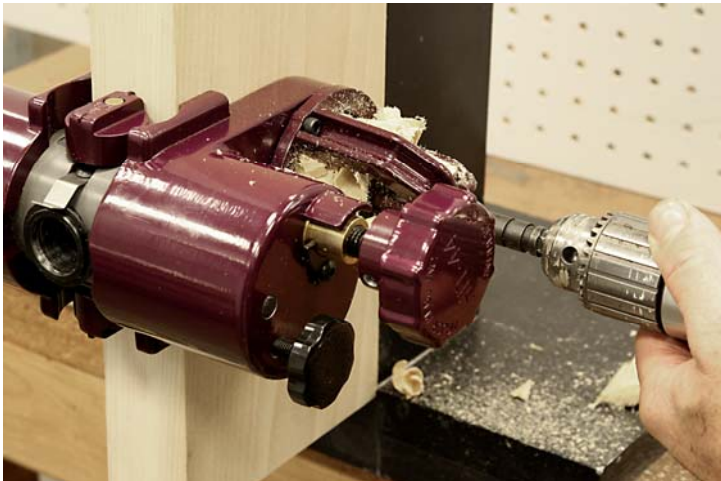

Drill the cross bore first using the proper size multi-spur bit and corresponding break out plate on the opposite side. USE A LOW RPM WHEN DRILLING AND BACK OUT THE BIT FROM TIME TO TIME TO REMOVE CHIP BUILDUP.



When the cross bore has been completed, drill the edge bore. Snap in the proper size bushing for the job.



We are using a 1 inch brad point bit for drilling the edge bore. Again use a low RPM and back out the bit to help remove chips.



Remove when completed.



Here we are using our HIT-44LM3 latch marking tool to mark the area for the faceplate. There is a 1/16" shim that is used to adjust to a 1" or 1-1/8" face. With the shims on the inside, this will mark a 1-1/8" face.



The use of a combination square will help to square the marker to the door.



Mark for the faceplate.



Use a sharp box cutter to deepen the vertical outline left by the marking tool. If you use a chisel for this step you run the risk of splitting out the side of the door.



A chisel can be used to deepen the top and bottom of the outlined area. Once everything has been outlined, chisel out the latch mortise.



Don't forget to mark the jamb for the strike plate. Shown is our HIT-44SL8 strike locator.



Use one of our centering drills to drill for the latch screw. This will assure a centered hole and will allow you to drive in the screw with out splitting the door. Do not attempt to drive in a screw without a pilot hole.



Install the lock per the manufacturers instructions.

Visit our web site at www.majormfg.com to see our complete line of tools and accessories. While there, sign up for our new product releases and we will email them direct to you.

HIT-44 DRILL MASTER COMPONENT PARTS

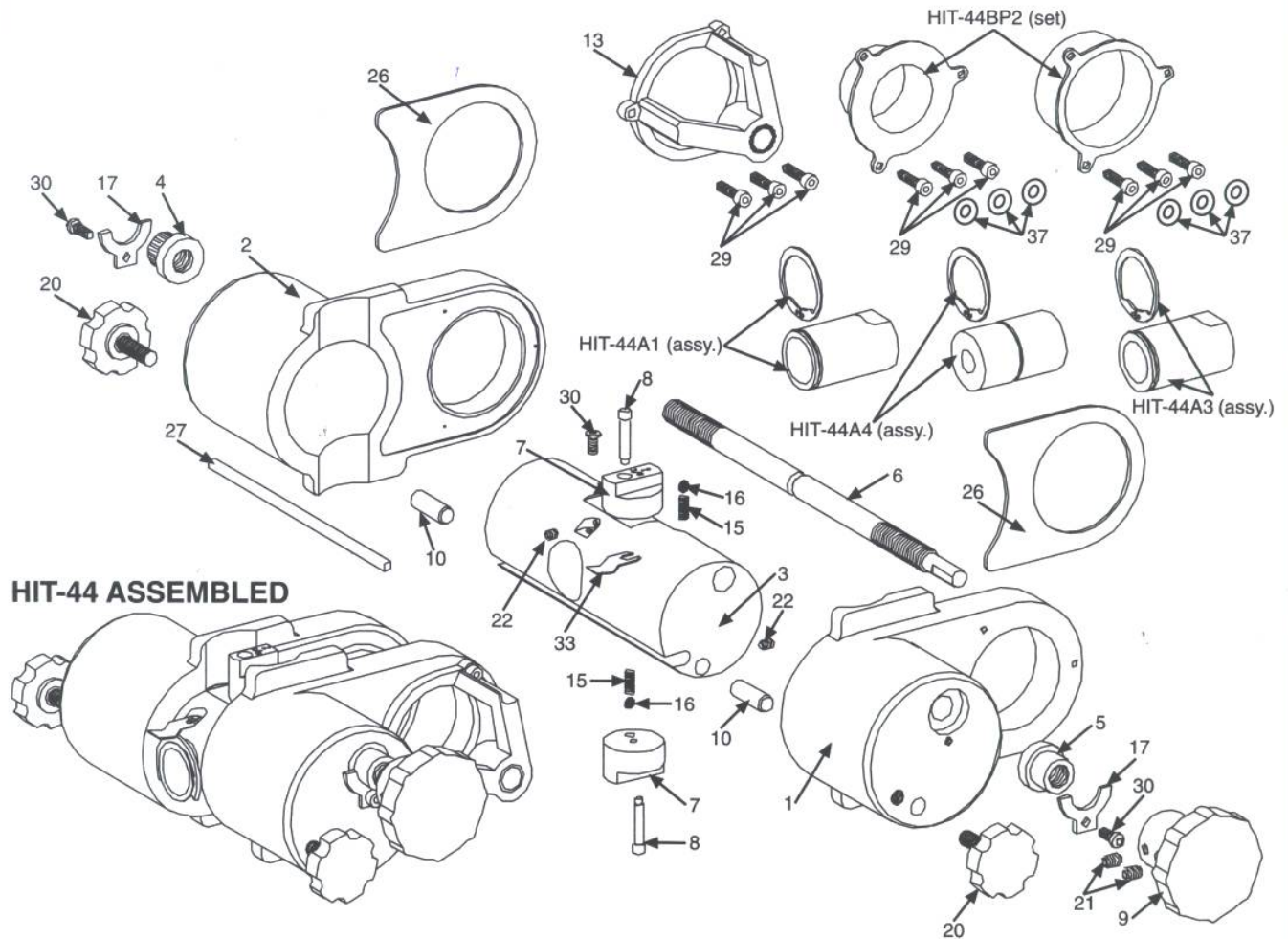

ITEM	PART NO.	DESCRIPTION	ITEM	PART NO.	DESCRIPTION	ITEM	PART NO.	DESCRIPTION
1	4401	R. Base	10	4410	Dowel Pin	27	4527	Shaft
2	4402	L. Base	13	4413	Multi-Spur Bit Guide	29	4429	Cap Screw
3	4403	Core	15	4415	Spring	30	4430	Button Head Screw
4	4404	Brass Knurled Nut	16	4416	Ball	33	4433	Bushing Clip
5	4405	L.H. Nut	17	4417	Screw Clamp	37	4437	Spacer Washer
6	4406	Lead Screw	20	4420	Cantilever Knob		HIT-44BP2	Hole Saw Guide/Breakout Plate (set)
7	4407	Back Space Knob	21	4421	Set Screw		HIT-44A1	1" Diameter Bushing
8	4408	Pin	22	4422	Set Screw		HIT-44A3	7/8" Diameter Bushing
9	4409	Main Clamp Knob	26	4426	Pad		HIT-44A4	1/2" Diameter Bushing

Major

MANUFACTURING, INC. • (714) 772-5202 • FAX (714) 772-2302